



Model: CSAC-150-D- \_1- \_2- \_3- \_4

### Descript

Dual refrigerant circuit / two stage air-cooled portable fluid chiller system. Chiller pump indicated on table is typical, with options available for different capacity.

CAPACITY		150,000 BTU /HR					
REFRIGERANT CIRCUIT(S) (QTY A/B)		2 (1/1)					
COMPRESSOR(S) / REFRIGERANT		(2) HERMETIC SCROLL / R-454B					
CONDENSER FANS / AIRFLOW		1 / 13,600 CFM					
CONDENSER COILS TYPE		ALUMINUM MICROCHANNEL					
EVAPORATOR TYPE		STAINLESS STEEL / COPPER BRAZED					
FLUID CONNECTIONS		2" MNPT (IN/OUT)					
ELECTRICAL:	V - Ø - HZ	COMP RLA / LRA (ea)	FAN FLA	PUMP FLA	MCA	MOCP	
- 5	230 - 3 - 60	A1/B1 22.4	190.0	3.6	5.6	63.2	80
- 6	460 - 3 - 60	A1/B1 11.5	100.0	3.6	2.8	31.6	40
CHILLER PUMP HP / OUTPUT		2.0 HP / 55 GPM @ 30 PSI					
TANK SIZE / CONSTRUCTION		41 GALLON / 304 STAINLESS STEEL VENTED TANK WITH LID					
DIMENSIONS		61.6" L x 38.6" W x 64.5" H					
WEIGHT (APPROX.)		1100 LBS					

### STANDARD FEATURES:

- **Controls:** Electronic temperature controller with constant Set Point & Process Value temperature readout. Programmable Logic Controller (PLC) with various temperature and pressure sensors to monitor refrigerant and fluid circuits. Optional Human Machine Interface (HMI) touch panel to provide visual display of system conditions.
- **Refrigeration Components:** Efficient scroll compressors, sight glass/moisture indicators, balanced port thermal expansion valves, filter driers, service valves and/or service ports, condenser fan(s) are electronically commutated motors (ECM) with variable speed control of head pressure.
- **Fluid Components:** Bronze "Y" strainers with 20 mesh stainless steel screen. Pumps are stainless steel centrifugal. All fluid components insulated. Vented tank includes lid, level sight glass and a fill and drain port. Portable systems will include a manually operated bypass valve.
- **Safety Controls:** High and low refrigerant pressures, high and low fluid temperatures, evaporator freeze condition, low water flow switch, thermal overloads and current monitors for compressors, and thermal overloads for fan motors, and current/thermal overload motor starter safety for pumps.
- **Construction:** Welded steel powder coated frame and full metal cabinet, copper piping connections.
- **Warranty:** One-year parts / five-year compressor.

### SUITABLE AMBIENT CONDITIONS/FEATURES: (see footnote 3)

- **IND:** Indoor use only. Casters on frame, Optional.
- **40:** Suitable for outdoor use with an ambient of 40°F ambient.
- **0:** Suitable for outdoor use to 0°F ambient.
- **M20:** Suitable for outdoor use to -20°F

### Notes:

- System capacity indicated on table is the approximate BTU/hr based on a leaving fluid temperature of 50°F with an ambient air temperature of 95°F.
- All specifications subject to change without notice. Specify voltage and ambient condition upon ordering.
- MCA: Minimum circuit amps per UL 1995. MOCP: Maximum overcurrent protective device per UL 1995.
- Pump outputs based on specific point on the pump curve which varies depending on system

<sup>1</sup> Flow Design (\_=Portable, ST=Stationary, RF=Reverse Flow, EXCH=Extra Heat Exchanger, DP=Dual Pump, DR=Dual Return)

<sup>2</sup> Leaving Fluid Temperature (\_=Standard, LT=Low Temperature-specify lowest temperature in °F)

<sup>3</sup> Ambient Temperature Conditions (see above)

<sup>4</sup> Electrical Power Code (see above)



# TECHNICAL SPECIFICATION

WWW.WATERCHILLERS.COM

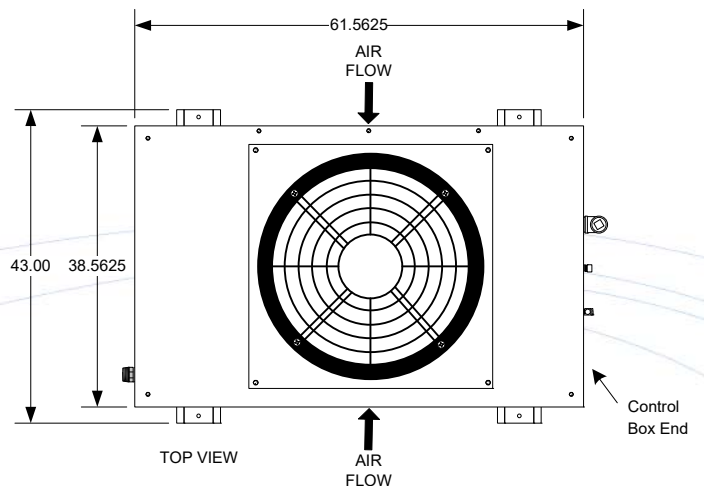
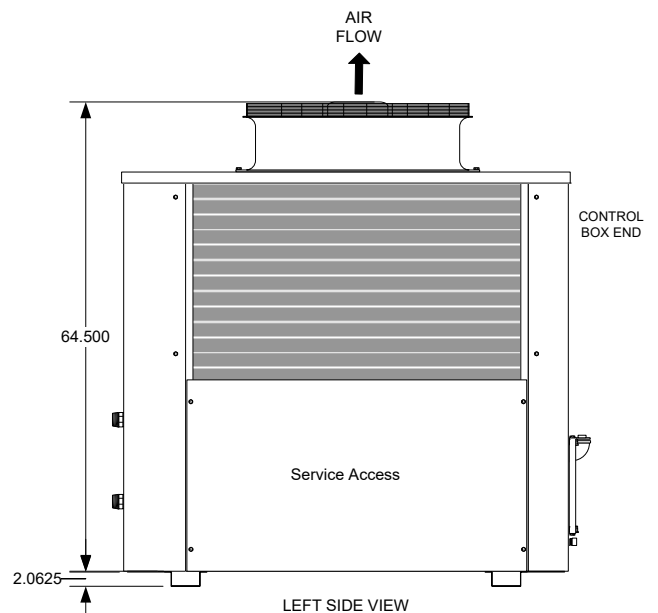
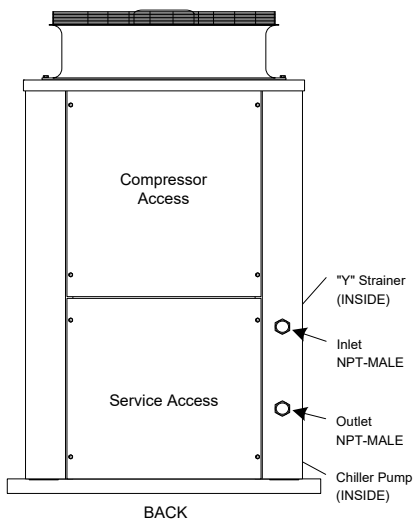
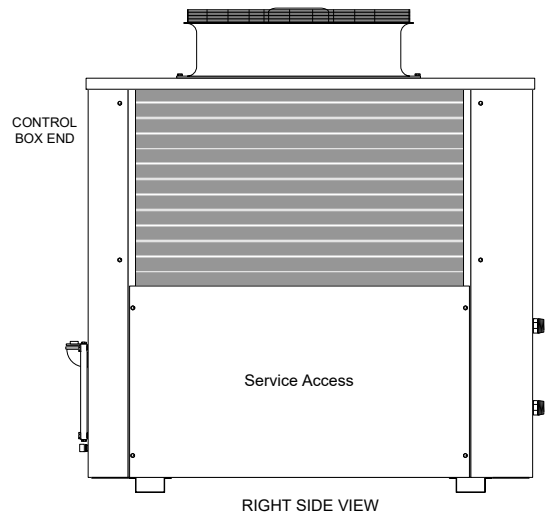
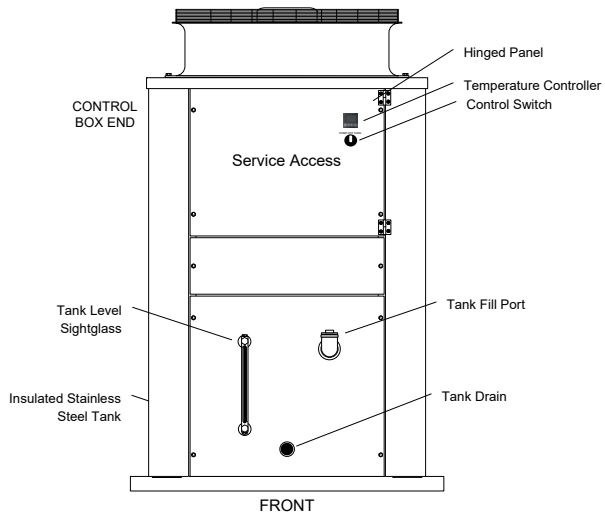

**NOTES**

- Unit should be installed with at least 4" clearance on all sides and a minimum of 8" clear air space above the unit
- Dimensions are approximate. (inches)
- Casters (Optional)
- All specifications subject to change without notice.

**COLD SHOT CHILLERS**

DRAWN ENGINEERING

ISSUED 12/11/2023

SIZE	DIMENSION NOTES
A	Dimensions are in inches Unless otherwise specified. +/-1/4"

DWG NO	REV
<b>INSTALLATION DRAWING</b> <b>CSAC-120-150- (Typical)</b>	1

SCALE	DWG-INST_CSAC-120-150-_-1022.vsd	SHEET	1 / Front-Back-Top-Sides
0.038in = 1in			



**STANDARD/PORTABLE/PACKAGE (-)**

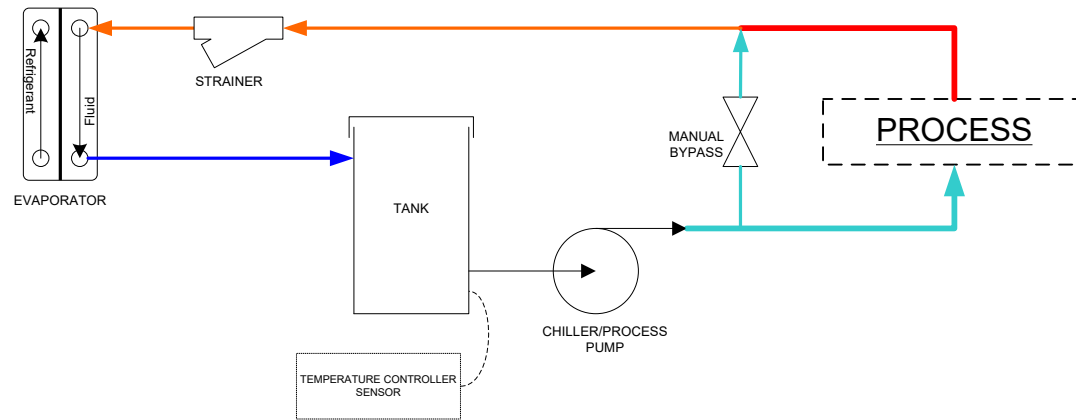

**Line Guide**

- COLD CHILLED FLUID
- HOT FLUID
- COLD FLUID
- WARM FLUID

**NOTES**

- All designs are subject to change without notice.
- The diagrams are to be used as a basic flow diagram only.
- Color Code is for relative temperature comparison.
- Additional components may be included.
- Evaporator may be located in tank.

<b>COLD SHOT CHILLERS</b>		SIZE	DESCRIPTION <b>Typical FLOW OPTIONS for Chiller Circuits</b>	REV		
		A		1		
DRAWN	ENGINEERING	SCALE	NONE	DWG-CKT_ChillerCircuitFlowOptions-Typical_(0520).vsd	SHEET	1 / Standard/Portable
ISSUED	5/2020					