



MODEL: CSAC-060-C-\_\_1\_\_2\_\_3\_\_4

**DESCRIPTION:**

Single refrigerant circuit / single stage air-cooled portable fluid chiller system setup. Chiller pump indicated on table is typical, with options available for different capacity.

CAPACITY		60,000 BTU /HR					
REFRIGERANT CIRCUIT(S)		1					
COMPRESSOR(S) / REFRIGERANT		HERMETIC SCROLL / R410A					
CONDENSER FAN(S) / AIRFLOW		1 / 3147 CFM					
CONDENSER COILS TYPE		ALUMINUM MICROCHANNEL					
EVAPORATOR TYPE		STAINLESS STEEL / COPPER BRAZED PLATE					
FLUID CONNECTIONS		1" MNPT (IN/OUT)					
ELECTRICAL:		COMPRESSOR(S)		FAN	PUMP		
	V - Ø - HZ	RLA	LRA	FLA	FLA	MCA	MOCP
- 2	230 - 1 - 60	30.1	145	3.0	6.6	47.2	70
- 5	230 - 3 - 60	23	160	3.0	3.4	35.1	50
- 6 <sup>5</sup>	460 - 3 - 60	12.2	87	3.0	1.7	19.9	30
CHILLER PUMP HP / OUTPUT		1.0 HP / 30 GPM @ 30 PSI					
TANK SIZE / CONSTRUCTION		25 GALLON / 304 STAINLESS STEEL VENTED TANK WITH LID					
DIMENSIONS		45" L x 32.5" W x 62.3" H					
WEIGHT (APPROX.)		650 LBS					

**STANDARD FEATURES:**

- **Controls:** Electronic temperature controller with constant Set Point & Process Value temperature readout.
- **Refrigeration Components:** Efficient scroll compressors, sight glass/moisture indicators, balanced port thermal expansion valves, filter driers, service valves, condenser fan(s) are electronically commutated motors. (ECM)
- **Fluid Components:** Bronze "Y" strainers with 20 mesh stainless steel screen. Pumps are stainless steel centrifugal. All fluid components insulated. Vented tank includes lid, level sight glass and a fill and drain port. Portable systems will include a manually operated bypass valve.
- **Safety Controls:** High and low refrigerant pressures, high and low fluid temperatures, evaporator freeze condition, low water flow switch, thermal overloads for compressors, and thermal overloads for fan motors, and current/thermal overload motor starter safety for pumps.
- **Construction:** Welded steel powder coated frame and full metal cabinet, copper piping connections.
- **Warranty:** One-year parts / five-year compressor.

**SUITABLE AMBIENT CONDITIONS/FEATURES: (see footnote 3)**

- **IND:** Indoor use only. Casters on frame, Optional.
- **40:** Suitable for outdoor use with an ambient of 40°F ambient.
- **0:** Suitable for outdoor use to 0°F ambient.
- **M20:** Suitable for outdoor use to -20°F ambient.

**Notes:**

- System capacity indicated on table is the approximate BTU/hr based on a leaving fluid temperature of 50°F with an ambient air temperature of 95°F.
- All specifications subject to change without notice. Specify voltage and ambient condition upon ordering.
- MCA: Minimum circuit amps per UL 1995. MOCP: Maximum overcurrent protective device per UL 1995.
- Pump outputs based on specific point on the pump curve which varies depending on system.

<sup>1</sup> Flow Design (\_=Portable, ST=Stationary, RF=Reverse Flow, EXCH=Extra Heat Exchanger, DP/DM=Dual Pump Medical, DR=Dual Return)

<sup>2</sup> Leaving Fluid Temperature (\_=Standard, LT=Low Temperature-specify lowest temperature in °F)

<sup>3</sup> Ambient Temperature Conditions (see above)

<sup>4</sup> Electrical Power Code (see above)

<sup>5</sup> Unit will require a 4-wire electrical service with neutral. If only 3 phase 3 wire 480-volt service is available, please notify our sales/technical support staff for proper installation procedures.



# TECHNICAL SPECIFICATION

WWW.WATERCHILLERS.COM

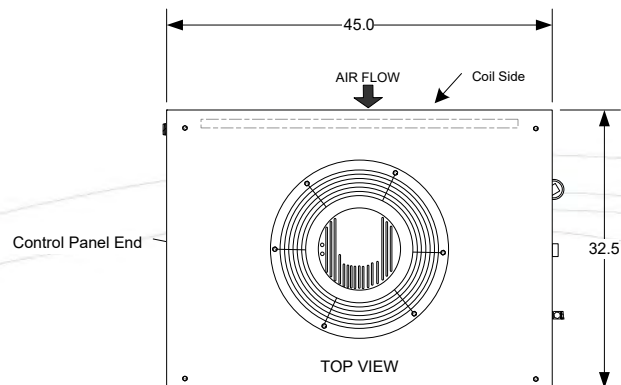
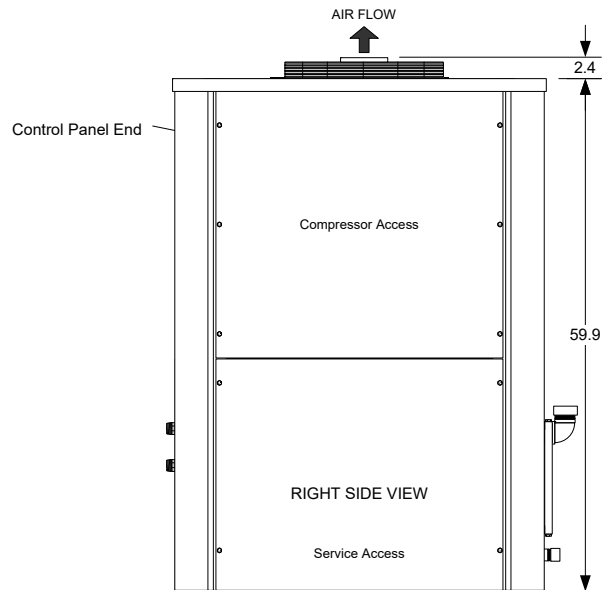
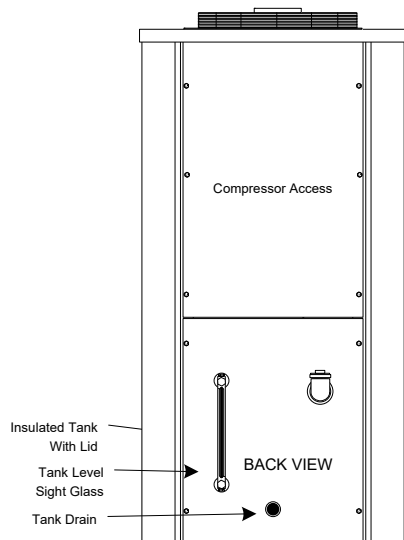
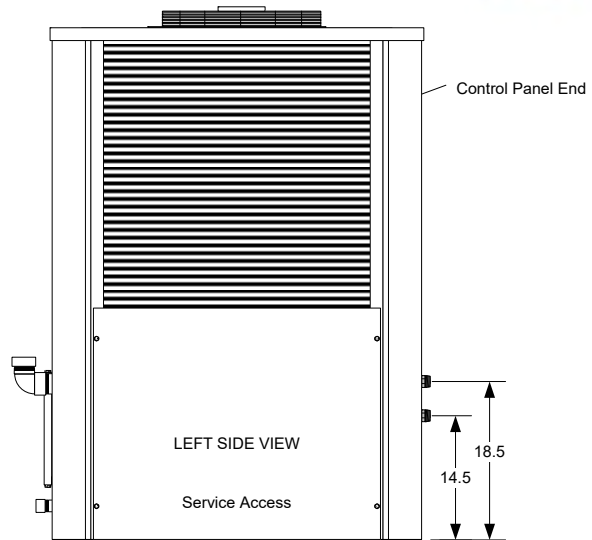
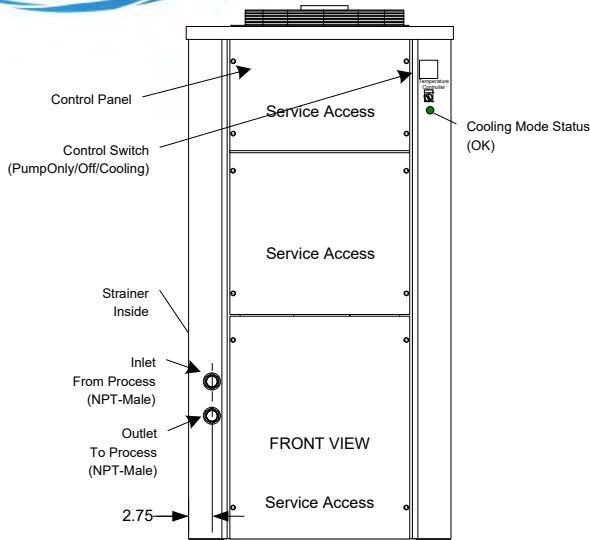

### NOTES

- Unit should be installed with at least 2' clearance on all sides and a minimum of 5' clear air space above the unit
- Dimensions are approximate. (inches)
- Casters (Optional)
- All specifications subject to change without notice.

## COLD SHOT CHILLERS

DRAWN ENGINEERING

ISSUED 2/17/2023

SIZE	DIMENSION NOTES
A	Dimensions are in inches Unless otherwise specified, +/-1/4"

DWG NO	REV
<b>INSTALLATION DRAWING</b> <b>CSAC-024 to 060- (Typical)</b>	1



**STANDARD/PORTABLE/PACKAGE (-)**

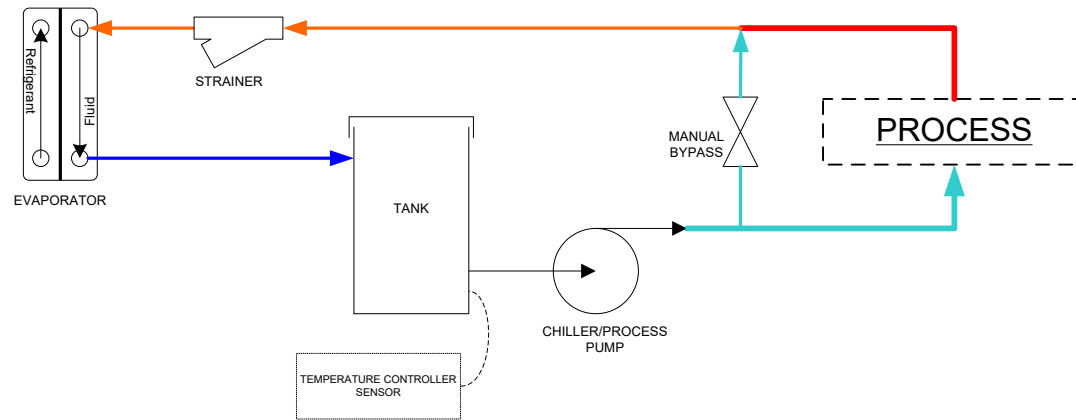

**Line Guide**

- COLD CHILLED FLUID
- HOT FLUID
- COLD FLUID
- WARM FLUID

**NOTES**

- All designs are subject to change without notice.
- The diagrams are to be used as a basic flow diagram only.
- Color Code is for relative temperature comparison.
- Additional components may be included.
- Evaporator may be located in tank.

**COLD SHOT CHILLERS**

DRAWN ENGINEERING

SIZE	A
------	---

DESCRIPTION  
**Typical FLOW OPTIONS for Chiller Circuits**

REV	1
-----	---

ISSUED 5/2020

SCALE NONE

DWG-CKT\_ChillerCircuitFlowOptions-Typical\_(0520).vsd

SHEET 1 / Standard/Portable