



Model: ACWC-720-GC-EXCH<sup>1</sup>-\_\_<sup>2</sup>-\_\_<sup>3</sup>-\_\_<sup>4</sup>

**Description:**

Five stage air-cooled portable water chiller system with additional process system heat exchanger. System capacity indicated on table is the approximate BTU/hr based on a leaving fluid temperature of 50°F with an ambient air temperature of 95°F.

CAPACITY		720,000 BTU /HR					
±5% AT 50° LCWT / 95°F AMBIENT							
COMPRESSOR / REFRIGERANT		(5) HERMETIC SCROLLS / R410A					
CONDENSER FANS / AIRFLOW		4 / 41,800 CFM					
CONDENSER COILS TYPE		MICROCHANNEL					
EVAPORATOR TYPE		STAINLESS STEEL / COPPER BRAZED					
HEAT EXCHANGER TYPE		STAINLESS STEEL / COPPER BRAZED					
FLUID CONNECTIONS		3" 150# FLANGE (IN/OUT)					
ELECTRICAL:	V - Ø - HZ	COMP RLA / LRA (ea)		FAN FLA (ea)	PUMP FLA	MCA	MOCP
- 5	230 - 3 - 60	A1/A2	55.8	340	6.6	17.5	313.7
		B1-B3	48.1	245			
- 6	460 - 3 - 60	A1/A2	26.9	179	3.3	8.7	138.2
		B1-B3	18.6	125			
CHILLER PUMP HP / OUTPUT		7.5 HP / 225 GPM @ 35 PSI					
TANK SIZE / CONSTRUCTION		625 GALLON / HIGH-DENSITY POLYETHYLENE					
DIMENSIONS		207" L x 88 ¼" W x 73" H					
WEIGHT (APPROX.)		3100 LBS					

Note: All specifications subject to change without notice. Specify voltage and ambient condition upon ordering.  
MCA: Minimum circuit amps per UL 1995. MOCP: Maximum overcurrent protective device per UL 1995.

**STANDARD FEATURES:**

- **Controls:** Electronic programmed temperature controller with constant (set point & process) temperature readout.
- **Refrigeration Components:** Efficient scroll compressors, sight glass/moisture indicators, balanced port expansion valves, filter drier, pump down valves, fan cycling head pressure controls.
- **Process Fluid Components:** Heat exchanger for separation of chilled fluid circuit from process fluid circuit. PVC "Y" strainer with 20 mesh stainless steel screen. Pumps are stainless steel centrifugal. Tanks are insulated with fluid level sensor, spin on lid and drain. Portable systems will include a flow control valve.
- **Safety Controls:** High and low refrigerant pressure, high and low fluid temperature, freeze, low water flow, internal overloads, thermal overload circuit breakers and/or safety fuses for compressors, pumps, and fan motors, temperature relief fusible plug on liquid lines of each circuit.
- **Construction:** Galvanized steel frame, powder coated carbon steel cabinet, PVC flange connections.
- **Warranty:** One year parts / five year compressor.

**SUITABLE AMBIENT CONDITIONS/FEATURES:**

- **IND:** Indoor use only.
- **40:** Suitable for outdoor use with an ambient of 40°F ambient.
- **0:** Suitable for outdoor use to 0°F ambient. Includes Low ambient fan speed controls with (LT) models.
- **M20:** Suitable for outdoor use to -20°F ambient. Includes Low ambient fan speed controls.

<sup>1</sup> Flow Design ( \_=Portable, ST=Stationary, RF=Reverse Flow, EXCH=Extra Heat Exchanger, DP=Dual Pump, DR=Dual Return)

<sup>2</sup> Leaving Fluid Temperature ( \_=Standard, LT=Low Temperature-specify lowest temperature in °F)

<sup>3</sup> Ambient Temperature Conditions (see above)

<sup>4</sup> Electrical Power Code (see above)



# TECHNICAL SPECIFICATION

WWW.WATERCHILLERS.COM

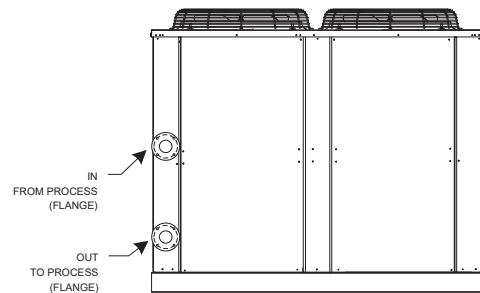
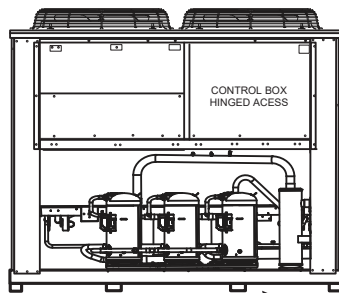
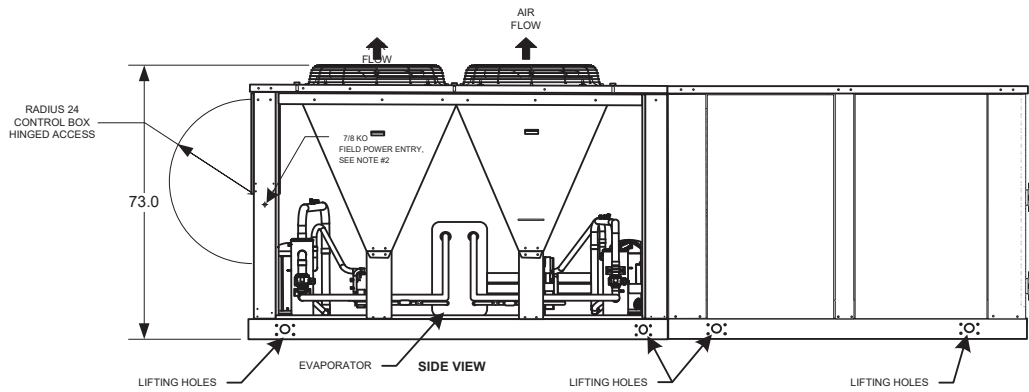
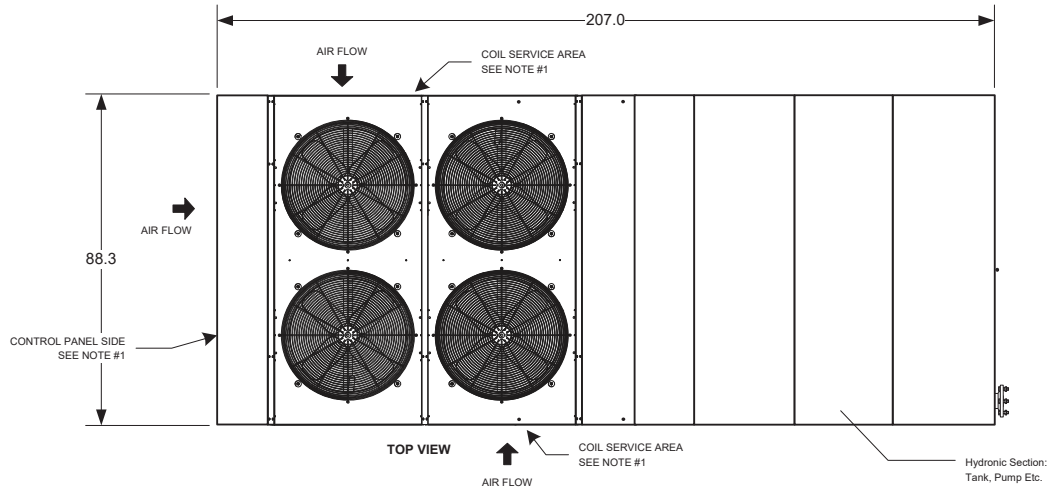
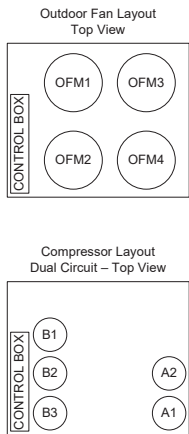

PAGE NOTES

- Unit must have minimum clearances for air flow/service access as follows: (air must be directed away from machine to prevent recirculating air back into machine coil sides.)
  - Top — Do not restrict in any way over condenser fan area.
  - Panel End — 4 ft per NEC.
  - Sides and End — 6 ft from solid surface for airflow.
  - Side — 8 ft required for coil service area.
- Field power supply connection: two 7/8 pilot holes provided. Actual hole required depend on field wire sizing.
- Temperature relief device located on suction line, liquid line and filter drier of each circuit are equipped with a 1/4" flare field connection.
- All chilled fluid piping should be insulated.
- Dimensions are in inches unless otherwise specified.
- Design and layout may change depending on parts or manufacturing without notice. Notify Cold Shot Chillers for any details needed based on construction.
- Contact Cold Shot Chillers for details or other information.
- Lifting:
  - System can be rigged with a crane. Approximate weights noted.
  - See lifting points on diagram below located on each side of chiller.
  - Not recommended for lifting with a forklift.

## COLD SHOT CHILLERS

DRAWN		ENGINEERING	SIZE	DIMENSION NOTES	DWG NO	REV
ISSUED		6/11/2020	A	Dimensions are in inches unless otherwise specified. +/-1/4"	<b>INSTALLATION DRAWING</b> <b>ACWC-720-GC (Typical - Front-Back-Top-Side-EXCH)</b>	1
SCALE		NONE	DWG-INST_-720-GC-EXCH_(0620).vsd		SHEET	1



# TECHNICAL SPECIFICATION

WWW.WATERCHILLERS.COM

## HEAT EXCHANGER (EXCH)

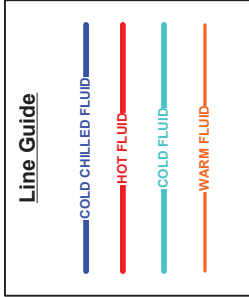
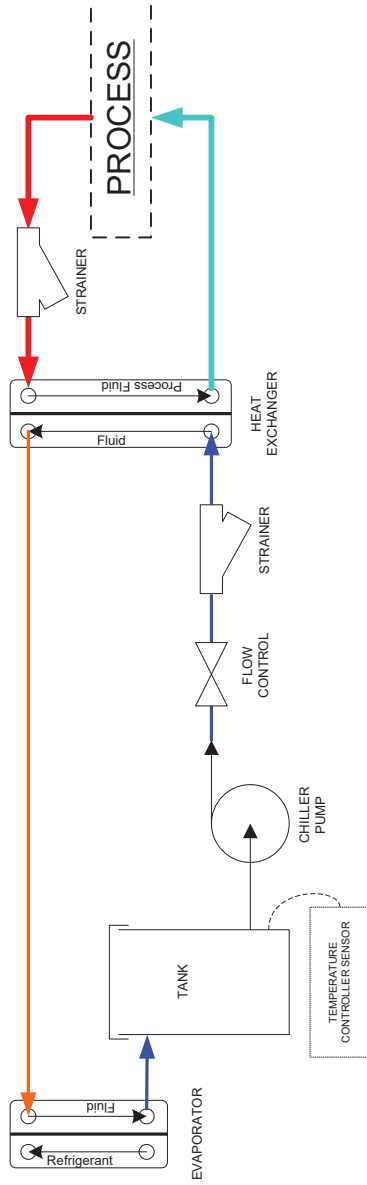

**NOTES**

- All designs are subject to change without notice.
- The diagrams are to be used as a basic flow diagram only.
- Color Code is for relative temperature comparison.
- Additional components may be included.
- Evaporator may be located in tank.

**COLD SHOT CHILLERS**

ENGINEERING

5/2020

DRAWN	DESCRIPTION		REV
	Typical FLOW OPTIONS for Chiller Circuits		1
ISSUED	SCALE	SHEET	Heat Exchanger (EXCH)
	NONE	DWG-CKT_ChillerCircuitFlowOptions-Typical_(0520)\vsd	2 /