



Model: ACWC-600-GC-RF<sup>1</sup>-  <sup>2</sup>-  <sup>3</sup>-  <sup>4</sup>

**Description:**

Five stage air-cooled water chiller system. System capacity indicated on table is the approximate BTU/hr based on a leaving fluid temperature of 50°F with an ambient air temperature of 95°F.

CAPACITY		600,000 BTU /HR					
±5% AT 50° LCWT / 95°F AMBIENT							
<b>COMPRESSOR / REFRIGERANT</b>		(5) HERMETIC SCROLLS / R410A					
<b>CONDENSER FANS / AIRFLOW</b>		4 / 41,800 CFM					
<b>CONDENSER COILS TYPE</b>		MICROCHANNEL					
<b>EVAPORATOR TYPE</b>		STAINLESS STEEL / COPPER BRAZED					
<b>FLUID CONNECTIONS</b>		3" 150# FLANGE (IN/OUT)					
<b>ELECTRICAL:</b>	<b>V - Ø - HZ</b>	<b>COMP RLA / LRA (ea)</b>		<b>FAN FLA (ea)</b>	<b>PUMP FLA</b>	<b>MCA</b>	<b>MOCP</b>
- 5	230 - 3 - 60	A1/A2	51.3	300	6.6	17.5	272.0
		B1/B2	55.8	340			
- 6	460 - 3 - 60	A1/A2	23.1	150	3.3	8.7	128.6
		B1/B2	26.9	179			
<b>CHILLER PUMP HP / OUTPUT</b>		7.5 HP / 250 GPM @ 35 PSI					
<b>DIMENSIONS</b>		92 ¼" L x 88 ¼" W x 73" H					
<b>WEIGHT (APPROX.)</b>		2750 LBS					

Note: All specifications subject to change without notice. Specify voltage and ambient condition upon ordering.  
MCA: Minimum circuit amps per UL 1995. MOCP: Maximum overcurrent protective device per UL 1995.

**STANDARD FEATURES:**

- **Controls:** Electronic programmed temperature controller with constant (set point & process) temperature readout.
- **Refrigeration Components:** Efficient scroll compressors, sight glass/moisture indicators, balanced port expansion valves, filter drier, pump down valves, fan cycling head pressure controls.
- **Process Fluid Components:** PVC "Y" strainer with 20 mesh stainless steel screen. Pumps are stainless steel centrifugal.
- **Safety Controls:** High and low refrigerant pressure, high and low fluid temperature, freeze, low water flow, internal overloads, thermal overload circuit breakers and/or safety fuses for compressors, pumps, and fan motors, temperature relief fusible plug on liquid lines of each circuit.
- **Construction:** Galvanized steel frame, powder coated carbon steel cabinet, PVC flange connections.
- **Warranty:** One year parts / five year compressor.

**SUITABLE AMBIENT CONDITIONS/FEATURES:**

- **IND:** Indoor use only.
- **40:** Suitable for outdoor use with an ambient of 40°F ambient.
- **0:** Suitable for outdoor use to 0°F ambient. Includes Low ambient fan speed controls with (LT) models.
- **M20:** Suitable for outdoor use to -20°F ambient. Includes Low ambient fan speed controls.

<sup>1</sup> Flow Design ( \_=Portable, ST=Stationary, RF=Reverse Flow, EXCH=Extra Heat Exchanger, DP=Dual Pump, DR=Dual Return)

<sup>2</sup> Leaving Fluid Temperature ( \_=Standard, LT=Low Temperature-specify lowest temperature in °F)

<sup>3</sup> Ambient Temperature Conditions (see above)

<sup>4</sup> Electrical Power Code (see above)



Outdoor Fan Layout  
Top View

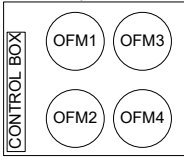

Compressor Layout  
Dual Circuit - Top View

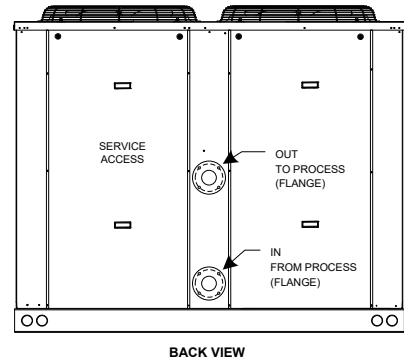
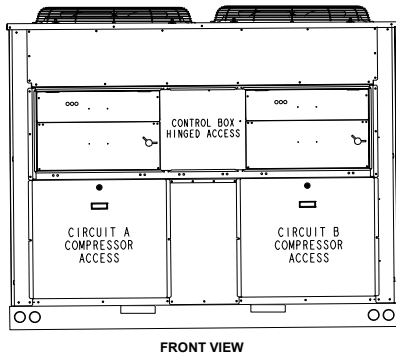
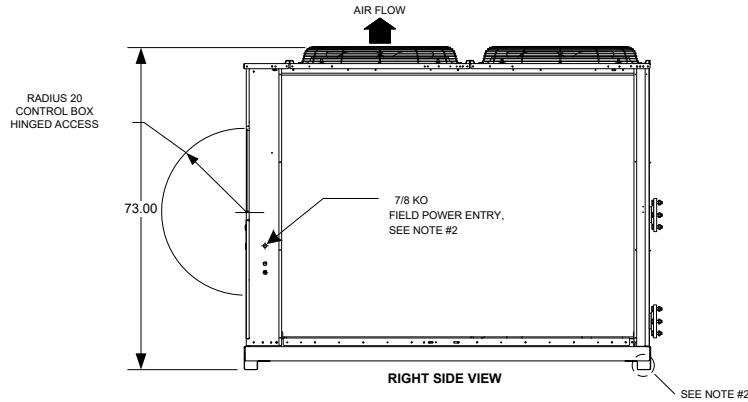
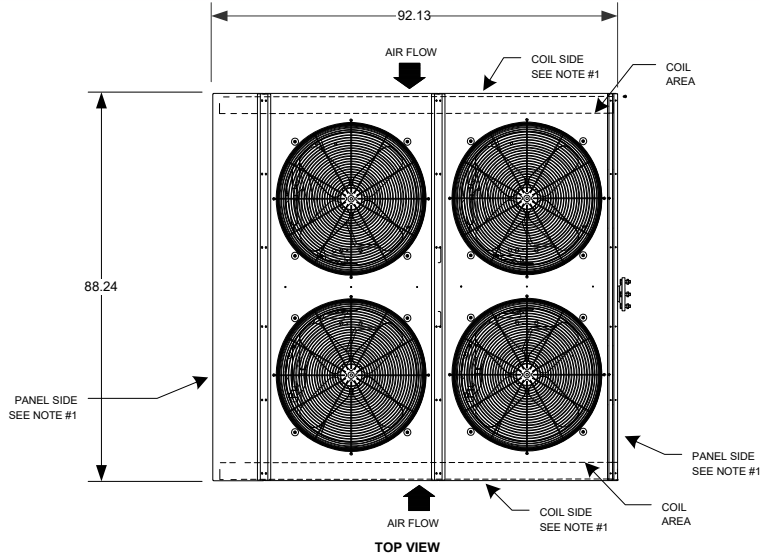
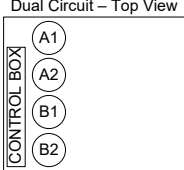

NOTES:

- Unit must have clearances for air flow/service access as follows: (air must be directed away from machine to prevent re-circulating air back into machine coil sides.)  
Top — Do not restrict.  
Coil End — 42 in. from solid surface for airflow.  
Panel Side — 48 in. per NEC (National Electrical Code).
- Mounting holes (17/32" Diameter) may be used to mount unit to concrete pad. They are not recommended for mounting unit to spring isolators.
- A 7/8 in. diameter hole is provided for locating field power wiring. Actual hole size required depends on field wire sizing.
- Temperature relief device located on suction line, liquid line of each circuit are equipped with a 1/4" flare field connection. Do not cap or otherwise obstruct temperature relief device.
- All chilled fluid piping should be insulated.
- Dimensions are in inches unless otherwise specified.
- Unit can be handled using the fork truck lift pockets.
- Design and layout may change depending on parts or manufacturing without notice.
- Contact Cold Shot Chillers for details or other information.

COLD SHOT CHILLERS

DRAWN ENGINEERING		SIZE A	DIMENSION NOTES Dimensions are in inches unless otherwise specified. +/-1/4"	DWG NO <b>INSTALLATION DRAWING</b> ACWC-600-GC (Typical - Front-Back-Side-Top)	REV 1
ISSUED	11/18/2021	SCALE	NONE	DWG-INST-600-GC-RF-(0620).vsd	SHEET 1



**REVERSE FLOW (RF)**

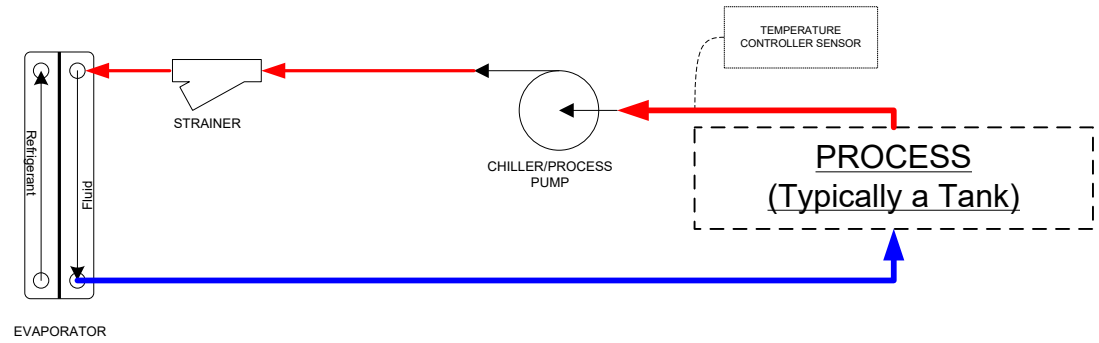

**Line Guide**

- COLD CHILLED FLUID
- HOT FLUID
- COLD FLUID
- WARM FLUID

**NOTES**

- All designs are subject to change without notice.
- The diagrams are to be used as a basic flow diagram only.
- Color Code is for relative temperature comparison.
- Additional components may be included.
- Evaporator may be located in tank.

**COLD SHOT CHILLERS**

DRAWN ENGINEERING

ISSUED 5/2020

SIZE A

SCALE NONE

DESCRIPTION  
**Typical FLOW OPTIONS for Chiller Circuits**

REV 1

DWG-CKT\_ChillerCircuitFlowOptions-Typical\_(0520).vsd

SHEET 3 / Reverse Flow (RF)