



Model: ACWC-480-GC-DP<sup>1</sup>-\_\_<sup>2</sup>-\_\_<sup>3</sup>-\_\_<sup>4</sup>

**Description:**

Three stage air-cooled portable water chiller system. Dual pump model includes one recirculating pump for the chiller circuit and a second pump dedicated for the process circuit. Process pump indicated on table is typical, with options available for different capacity. System capacity indicated on table is the approximate BTU/hr based on a leaving fluid temperature of 50°F with an ambient air temperature of 95°F.

<b>CAPACITY</b>		<b>480,000 BTU /HR</b>						
±5% AT 50° LCWT / 95°F AMBIENT								
<b>COMPRESSOR / REFRIGERANT</b>		TANDEM HERMETIC SCROLLS / R410A						
<b>CONDENSER FANS / AIRFLOW</b>		3 / 32,000 CFM						
<b>CONDENSER COILS TYPE</b>		MICROCHANNEL						
<b>EVAPORATOR TYPE</b>		STAINLESS STEEL / COPPER BRAZED						
<b>FLUID CONNECTIONS</b>		2" MNPT (IN/OUT)						
<b>ELECTRICAL:</b>	<b>V - Ø - HZ</b>	<b>COMP RLA / LRA (ea)</b>		<b>FAN FLA (ea)</b>	<b>(No*) PUMP FLA</b>		<b>MCA</b>	<b>MOCP</b>
- 5	230 - 3 - 60	51.3	300	6.6	(1) 12.2	(2) 12.2	210.9	250
- 6	460 - 3 - 60	23.1	150	3.3	(1) 6.1	(2) 6.1	97.1	110
<b>CHILLER PUMP HP / OUTPUT (1)</b>		5.0 HP / 135 GPM @ 30 PSI						
<b>PROCESS PUMP HP / OUTPUT (2)</b>		5.0 HP / 135 GPM @ 30 PSI						
<b>TANK SIZE / CONSTRUCTION</b>		220 GALLON / 304 STAINLESS STEEL TANK WITH LID						
<b>DIMENSIONS</b>		92 ¼" L x 88 ¼" W x 73" H						
<b>WEIGHT (APPROX.)</b>		3100 LBS						

Note: All specifications subject to change without notice. Specify voltage and ambient condition upon ordering.  
MCA: Minimum circuit amps per UL 1995. MOCP: Maximum overcurrent protective device per UL 1995.

**STANDARD FEATURES:**

- **Controls:** Electronic programmed temperature controller with constant (set point & process) temperature readout.
- **Refrigeration Components:** Efficient scroll compressors, sight glass/moisture indicators, balanced port expansion valves, filter drier, pump down valves, fan cycling head pressure controls.
- **Process Fluid Components:** Bronze "Y" strainer with 20 mesh stainless steel screen. Pumps are stainless steel centrifugal. Tanks are insulated with shoe box lid, fill port, and fluid level sensor. Portable systems will include a flow control valve.
- **Safety Controls:** High and low refrigerant pressure, high and low fluid temperature, freeze, low water flow, internal overloads, thermal overload circuit breakers and/or safety fuses for compressors, pumps, and fan motors, temperature relief fusible plug on liquid lines of each circuit.
- **Construction:** Galvanized steel frame, powder coated carbon steel cabinet, copper piping connections.
- **Warranty:** One year parts / five year compressor.

**SUITABLE AMBIENT CONDITIONS/FEATURES:**

- **IND:** Indoor use only.
- **40:** Suitable for outdoor use with an ambient of 40°F ambient.
- **0:** Suitable for outdoor use to 0°F ambient. Includes Low ambient fan speed controls with (LT) models.
- **M20:** Suitable for outdoor use to -20°F ambient. Includes Low ambient fan speed controls. External wind baffles, optional.

<sup>1</sup> Flow Design (\_\_=Portable, ST=Stationary, RF=Reverse Flow, EXCH=Extra Heat Exchanger, DP=Dual Pump, DR=Dual Return)

<sup>2</sup> Leaving Fluid Temperature (\_\_=Standard, LT=Low Temperature-specify lowest temperature in °F)

<sup>3</sup> Ambient Temperature Conditions (see above)

<sup>4</sup> Electrical Power Code (see above)



# TECHNICAL SPECIFICATION

WWW.WATERCHILLERS.COM

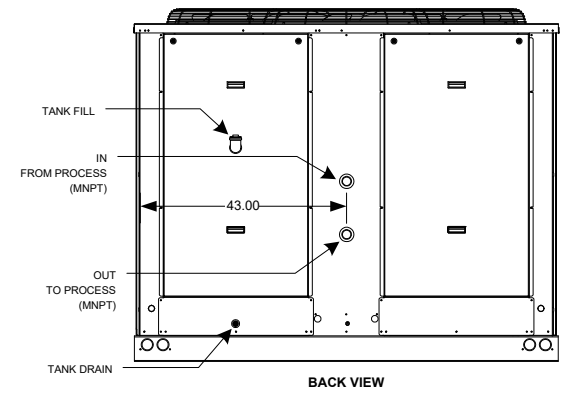
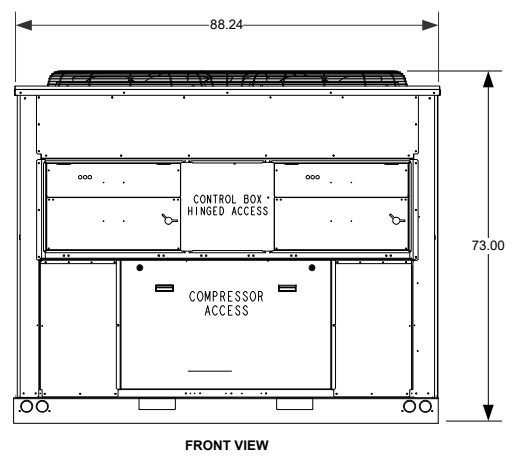
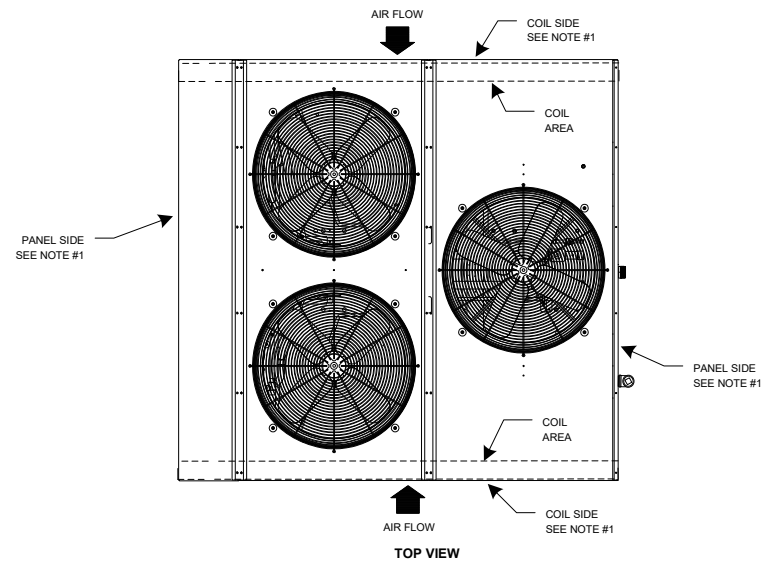
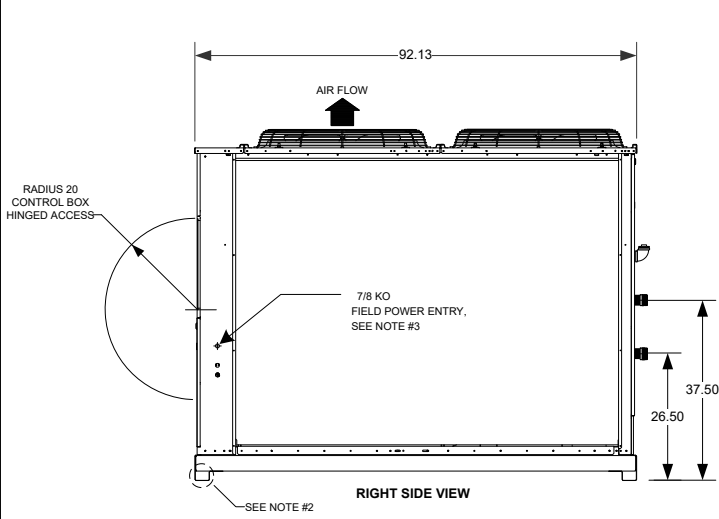

**NOTES:**

1. Unit must have clearances for air flow/service access as follows: (air must be directed away from machine to prevent re-circulating air back into machine coil sides.)  
 Top — Do not restrict.  
 Coil End — 42 in. from solid surface for airflow.  
 Panel Side — 48 in. per NEC (National Electrical Code).
2. Mounting holes (17/32" Diameter) may be used to mount unit to concrete pad. They are not recommended for mounting unit to spring isolators.
3. A 7/8 in. diameter hole is provided for locating field power wiring. Actual hole size required depends on field wire sizing.
4. Temperature relief device located on suction line, liquid line of each circuit are equipped with a 1/4" flare field connection. Do not cap or otherwise obstruct temperature relief device.
5. All chilled fluid piping should be insulated.
6. Dimensions are in inches unless otherwise specified.
7. Unit can be handled using the fork truck lift pockets.
8. Design and layout may change depending on parts or manufacturing without notice.
9. Contact Cold Shot Chillers for details or other information.

Outdoor Fan Layout  
Top View

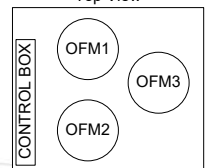

Compressor Layout  
Single Circuit – Top View

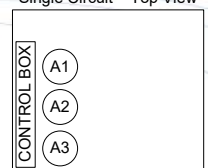

## COLD SHOT CHILLERS

DRAWN ENGINEERING		SIZE A	DIMENSION NOTES Dimensions are in inches unless otherwise specified. +/-1/4"	DWG NO	REV
ISSUED 11/18/2021		SCALE NONE	DWG-INST_ACWC-480-GC---_(0520) .vsd	<b>INSTALLATION DRAWING</b> <b>ACWC-480-GC (Typical - Front-Back-Side-Top)</b>	
			SHEET	1	



**DUAL PUMP (DP)**

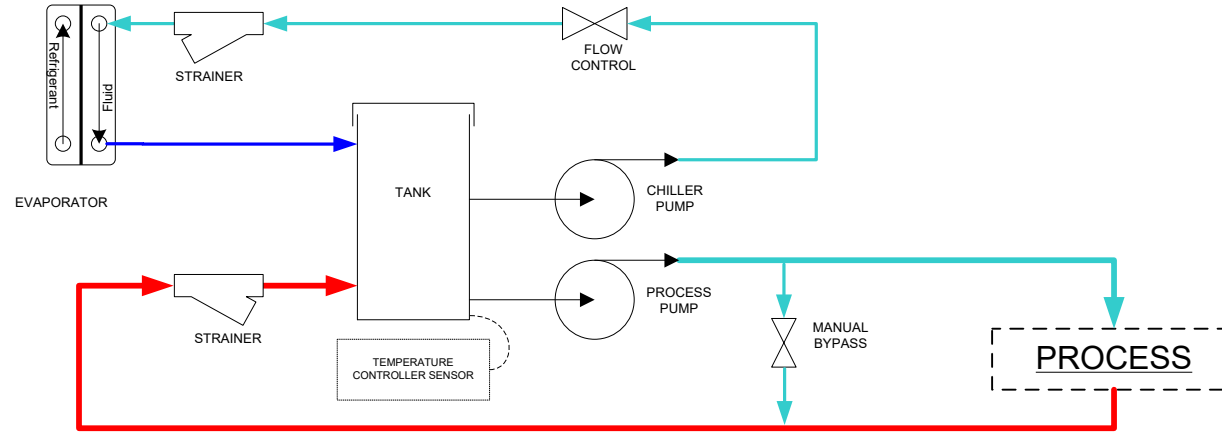

**Line Guide**

- COLD CHILLED FLUID
- HOT FLUID
- COLD FLUID
- WARM FLUID

**NOTES**

- All designs are subject to change without notice.
- The diagrams are to be used as a basic flow diagram only.
- Color Code is for relative temperature comparison.
- Additional components may be included.
- Evaporator may be located in tank.

**COLD SHOT CHILLERS**

DRAWN ENGINEERING

ISSUED 5/2020

SIZE A

SCALE NONE

DESCRIPTION  
**Typical FLOW OPTIONS for Chiller Circuits**

REV 1

DWG-CKT\_ChillerCircuitFlowOptions-Typical\_(0520).vsd

SHEET 6 / Dual Pump (DP)