



Model: ACWC-240-E-DM¹-__2-__3-__4

Description:

Three stage air-cooled portable water chiller system. Dual pump model includes one recirculating pump for the chiller circuit and a second pump dedicated for the process circuit. Process pump indicated on table is typical, with options available for different capacity. System capacity indicated on table is the approximate BTU/hr based on a leaving fluid temperature of 50°F with an ambient air temperature of 95°F.

CAPACITY ±5% AT 50° LCWT / 95°F AMBIENT		240,000 BTU /HR							
COMPRESSOR / REFRIGERANT		TANDEM HERMETIC SCROLL / R410A							
CONDENSER FANS / AIRFLOW		3 / 12000 CFM							
CONDENSER COILS TYPE		COPPER TUBE / ALUMINUM FIN							
EVAPORATOR TYPE		STAINLESS STEEL / COPPER BRAZED							
FLUID CONNECTIONS		1 ¼" MNPT (IN/OUT)							
ELECTRICAL:	V - Ø - HZ	COMP RLA / LRA (ea)		FAN FLA (ea)		(No*) PUMP FLA		MCA	MOCP
- 5	230 - 3 - 60	33.3	239	2.4	(1) 5.6	(2) 5.6	93.3	125	
- 6	460 - 3 - 60	17.9	125	1.1	(1) 2.8	(2) 2.8	49.1	60	
CHILLER PUMP HP / OUTPUT (1)		2.0 HP / 60 GPM @ 30 PSI							
PROCESS PUMP HP / OUTPUT (2)		2.0 HP / 32 GPM @ 45 PSI							
TANK SIZE / CONSTRUCTION		80 GALLON / 304 STAINLESS STEEL TANK WITH LID							
DIMENSIONS		88" L x 40" W x 70" H							
WEIGHT (APPROX.)		2300 LBS							

Note: All specifications subject to change without notice. Specify voltage and ambient condition upon ordering.

MCA: Minimum circuit amps per UL 1995. MOCP: Maximum overcurrent protective device per UL 1995.

STANDARD FEATURES:

- **Controls:** Electronic programmed temperature controller with constant (set point & process) temperature readout.
- **Refrigeration Components:** Efficient scroll compressors, sight glass/moisture indicators, balanced port expansion valves, filter drier, pump down valves, fan cycling head pressure controls. Hot gas bypass for capacity control.
- **Process Fluid Components:** Bronze "Y" strainer with 20 mesh stainless steel screen. Pumps are stainless steel centrifugal. Tanks are insulated with shoe box lid, fill port, and level sight glass. Portable systems will include a flow control valve.
- **Safety Controls:** High and low refrigerant pressure, high and low fluid temperature, freeze, low water flow, overloads for compressor and fan motors, safety fuses or overloads for pump.
- **Construction:** Welded steel powder coated frame and full metal cabinet, copper piping connections.
- **Warranty:** One year parts / five year compressor.

SUITABLE AMBIENT CONDITIONS/FEATURES:

- **IND:** Indoor use only. Casters on frame.
- **40:** Suitable for outdoor use with an ambient of 40°F ambient. Includes Heat trace cable.
- **0:** Suitable for outdoor use to 0°F ambient. Includes Heat trace cable.
- **M20:** Suitable for outdoor use to -20°F ambient. Includes Low ambient fan speed controls, Heat trace cable. External wind baffles, optional

Available Options:

- | | | |
|---|---|--|
| - Automatic City Water Switchover Panel | - Remote Status Panel | - Compressed Air System |
| - Manual City Water Switchover (Internal or External/Panel) | - Panel Mount Water, Refrigeration, and Air Pressure Gauges | - Vibration eliminators on all outside connections |
| - Operating & Safety Indicator lights | - Pump capacity upgrade | - 150 Micron City Water Filter |
| - City Water Audible Alarm | - Phase Monitoring Safety | - 150 Micron Chill Water Filter |

¹ Flow Design (__=Portable, ST=Stationary, RF=Reverse Flow, EXCH=Extra Heat Exchanger, DM=Dual Pump Medical, DR=Dual Return)

² Leaving Fluid Temperature (__=Standard, LT=Low Temperature-specify lowest temperature in °F)

³ Ambient Temperature Conditions (see above)

⁴ Electrical Power Code (see above)



TECHNICAL SPECIFICATION

WWW.WATERCHILLERS.COM

LEFT

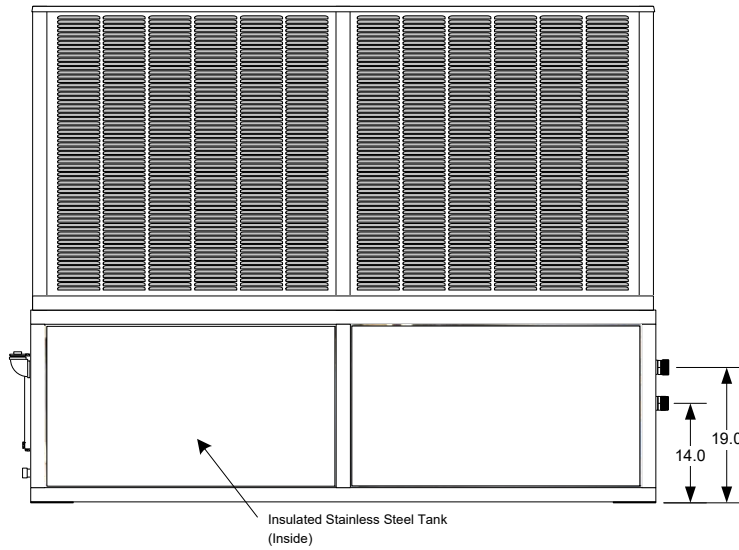

FRONT

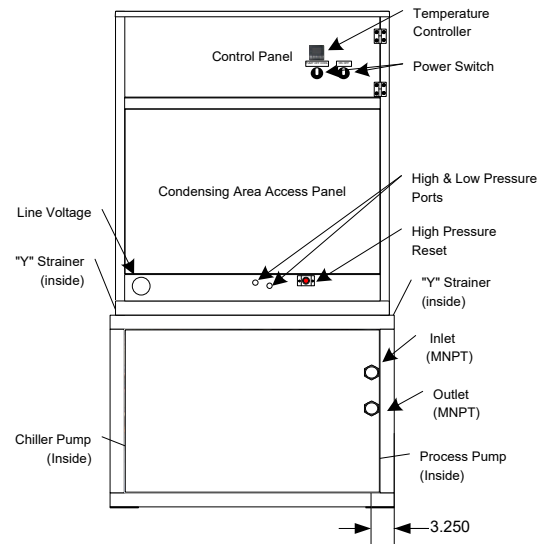

RIGHT

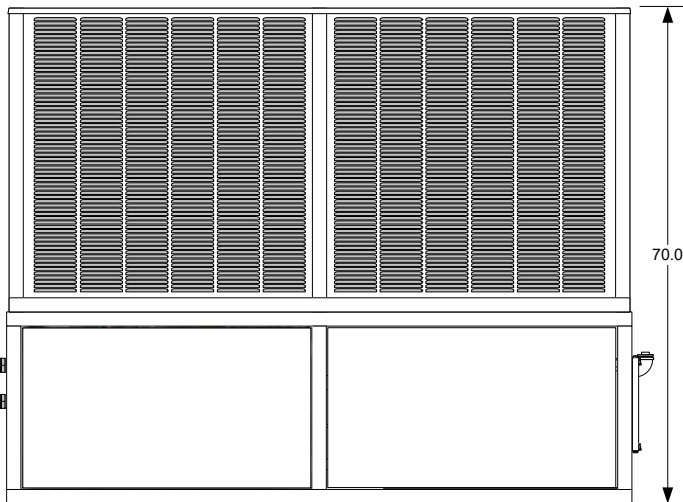

BACK

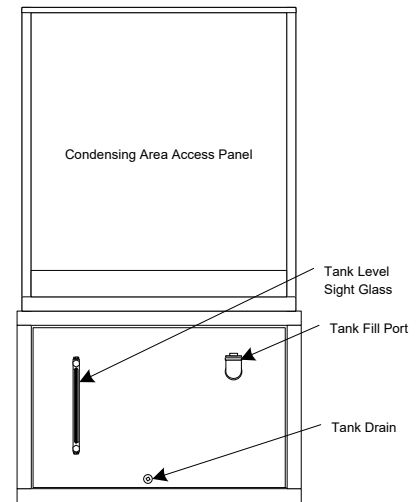

TOP

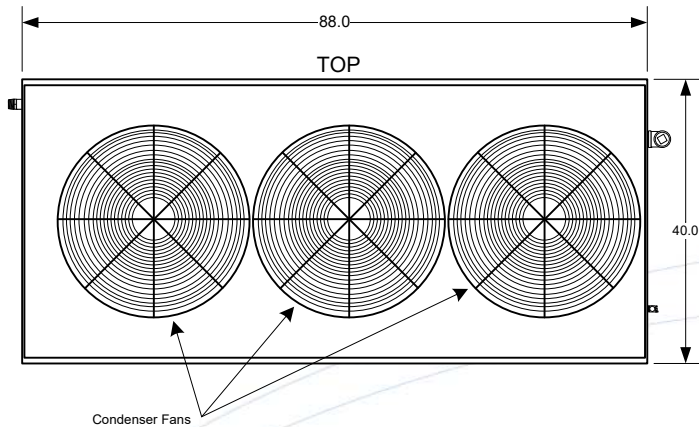

NOTES

- Unit should be installed with at least 4' clearance on all sides and a minimum of 8' clear air space above the unit
- Dimensions are approximate. (inches)
- Casters (Optional)
- All specifications subject to change without notice.

COLD SHOT CHILLERS

DRAWN ENGINEERING

ISSUED 5/26/2020

SIZE A
DIMENSION NOTES
Dimensions are in inches
Unless otherwise specified. +/-1/4"

SCALE NONE

DWG NO

INSTALLATION DRAWING
ACWC-180-240-E- (Typical)

DWG-INST_ACWC-180-240-E-(0520).vsd

REV

1

SHEET 2 / Front-Back-Top-Sides_DP



DUAL PUMP (DP)

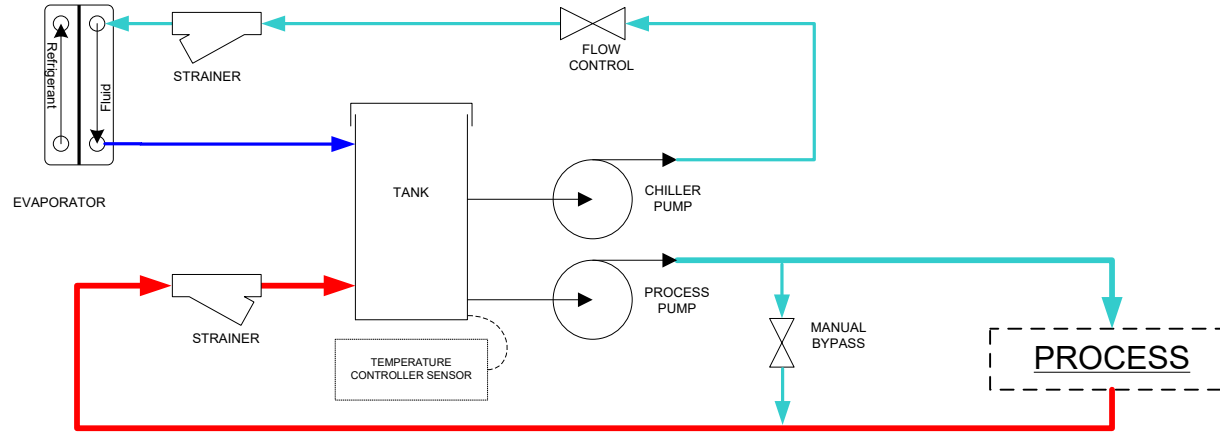

Line Guide

- COLD CHILLED FLUID
- HOT FLUID
- COLD FLUID
- WARM FLUID

NOTES

- All designs are subject to change without notice.
- The diagrams are to be used as a basic flow diagram only.
- Color Code is for relative temperature comparison.
- Additional components may be included.
- Evaporator may be located in tank.

COLD SHOT CHILLERS

DRAWN ENGINEERING

ISSUED 5/2020

SIZE A

SCALE NONE

DESCRIPTION
Typical FLOW OPTIONS for Chiller Circuits

REV 1

DWG-CKT_ChillerCircuitFlowOptions-Typical_(0520).vsd

SHEET 6 / Dual Pump (DP)