



Model: ACWC-120-Q-__1-__2-__3-__4

Description:

Two stage air-cooled portable water chiller system. System capacity indicated on table is the approximate BTU/hr based on a leaving fluid temperature of 50°F with an ambient air temperature of 95°F.

| CAPACITY | | 120,000 BTU /HR | | | | | |
|---------------------------------|-------------------|---|---------------------|-----------------|------------|-------------|----|
| ±5% AT 50° LCWT / 95°F AMBIENT | | | | | | | |
| COMPRESSOR / REFRIGERANT | | HERMETIC SCROLL / R410A | | | | | |
| CONDENSER FANS / AIRFLOW | | 2 / 8000 CFM | | | | | |
| CONDENSER COILS TYPE | | COPPER TUBE / ALUMINUM FIN | | | | | |
| EVAPORATOR TYPE | | STAINLESS STEEL / COPPER BRAZED | | | | | |
| FLUID CONNECTIONS | | 1 ¼" MNPT (IN/OUT) | | | | | |
| ELECTRICAL: | V - Ø - HZ | COMP RLA / LRA | FAN FLA (ea) | PUMP FLA | MCA | MOCP | |
| - 5 | 230 - 3 - 60 | 32.6 | 240 | 3.5 | 5.0 | 52.7 | 80 |
| - 6 | 460 - 3 - 60 | 14.8 | 130 | 1.5 | 2.5 | 24 | 35 |
| PUMP HP / OUTPUT | | 1.5 HP / 40 GPM @ 34.6 PSI | | | | | |
| TANK SIZE / CONSTRUCTION | | 41 GALLON / 304 STAINLESS STEEL TANK WITH LID | | | | | |
| DIMENSIONS | | 73 ½" L x 39 ½" W x 67" H | | | | | |
| WEIGHT (APPROX.) | | 1500 LBS | | | | | |

Note: All specifications subject to change without notice. Specify voltage and ambient condition upon ordering.
MCA: Minimum circuit amps per UL 1995. MOCP: Maximum overcurrent protective device per UL 1995.

STANDARD FEATURES:

- **Controls:** Electronic programmed temperature controller with constant (set point & process) temperature readout.
- **Refrigeration Components:** Efficient scroll compressors, sight glass/moisture indicators, balanced port expansion valves, filter drier, pump down valves, fan cycling head pressure controls.
- **Process Fluid Components:** Bronze "Y" strainer with 20 mesh stainless steel screen. Pumps are stainless steel centrifugal. Tanks are insulated with shoe box lid, fill port, and level sight glass. Portable systems will include a bypass flow valve.
- **Safety Controls:** High and low refrigerant pressure, high and low fluid temperature, freeze, low water flow, overloads for compressor and fan motors, safety fuses or overloads for pump.
- **Construction:** Welded steel powder coated frame and full metal cabinet, copper piping connections.
- **Warranty:** One year parts / five year compressor.

SUITABLE AMBIENT CONDITIONS/FEATURES:

- **IND:** Indoor use only. Casters on frame.
- **40:** Suitable for outdoor use with an ambient of 40°F ambient.
- **0:** Suitable for outdoor use to 0°F ambient.
- **M20:** Suitable for outdoor use to -20°F ambient. Includes hot gas bypass. External wind baffles, optional.

¹ Flow Design (__=Portable, ST=Stationary, RF=Reverse Flow, EXCH=Extra Heat Exchanger, DP=Dual Pump, DR=Dual Return)

² Leaving Fluid Temperature (__=Standard, LT=Low Temperature-specify lowest temperature in °F)

³ Ambient Temperature Conditions (see above)

⁴ Electrical Power Code (see above)



TECHNICAL SPECIFICATION

WWW.WATERCHILLERS.COM

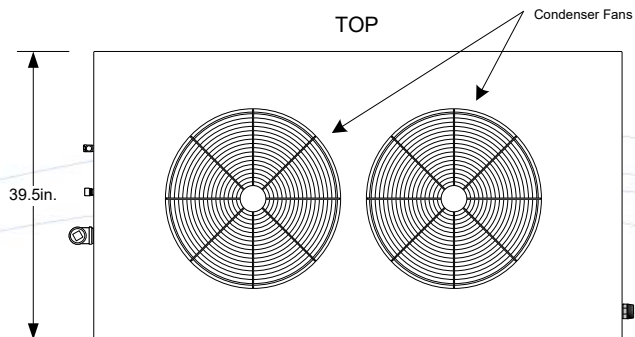
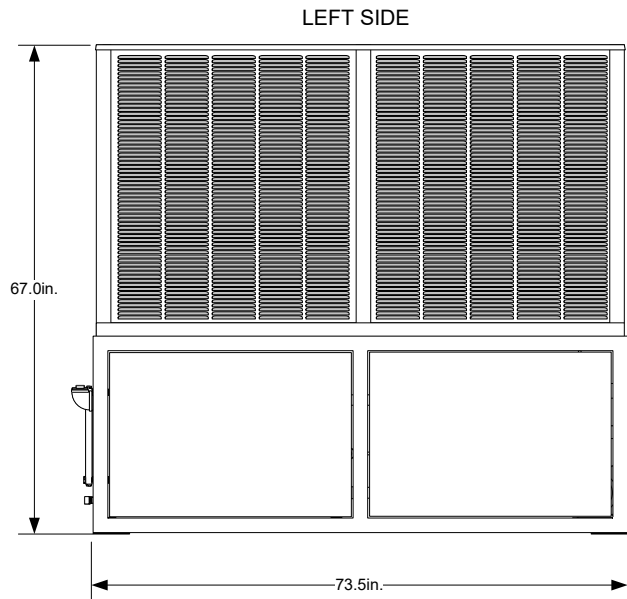
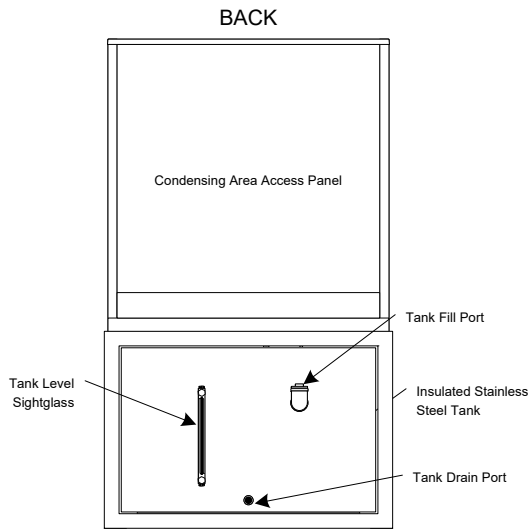
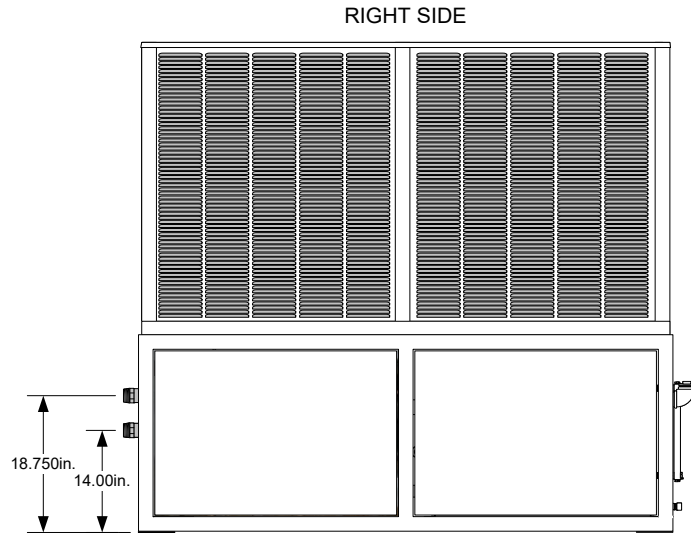
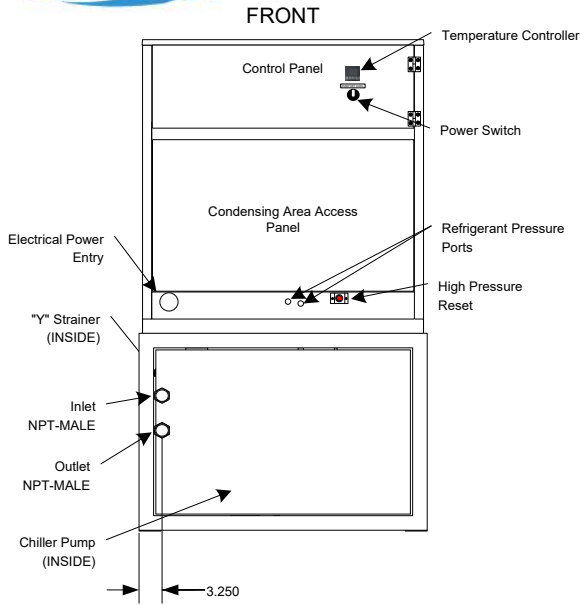

NOTES

- Unit should be installed with at least 4' clearance on all sides and a minimum of 8' clear air space above the unit
- Dimensions are approximate. (inches)
- Casters (Optional)
- All specifications subject to change without notice.

COLD SHOT CHILLERS

DRAWN ENGINEERING

ISSUED 11/18/2021

| SIZE | DIMENSION NOTES |
|------|--|
| A | Dimensions are in inches Unless otherwise specified. $\pm 1/4"$ |

| DWG NO | REV |
|---|-----|
| INSTALLATION DRAWING ACWC-120-Q_ (Typical) | 1 |

| | | | | |
|-------|------|--------------------------------|-------|--------------------------|
| SCALE | NONE | DWG-INST_ACWC-120-Q-(0520).vsd | SHEET | 1 / Front-Back-Top-Sides |
|-------|------|--------------------------------|-------|--------------------------|



STANDARD/PORTABLE/PACKAGE (-)

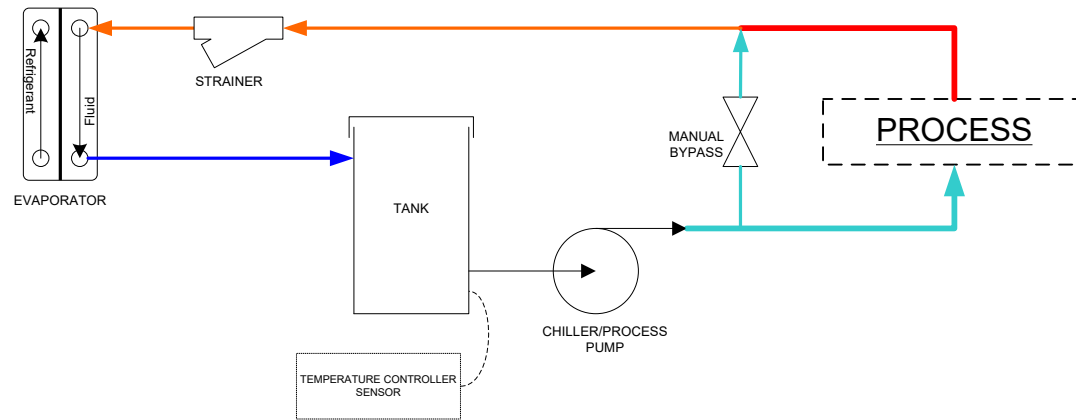

Line Guide

- COLD CHILLED FLUID
- HOT FLUID
- COLD FLUID
- WARM FLUID

NOTES

- All designs are subject to change without notice.
- The diagrams are to be used as a basic flow diagram only.
- Color Code is for relative temperature comparison.
- Additional components may be included.
- Evaporator may be located in tank.

COLD SHOT CHILLERS

DRAWN ENGINEERING

ISSUED 5/2020

SIZE A

SCALE NONE

DESCRIPTION
Typical FLOW OPTIONS for Chiller Circuits

REV 1

DWG-CKT_ChillerCircuitFlowOptions-Typical_(0520).vsd

SHEET 1 / Standard/Portable