



Model: ACWC-090-Q-EXCH¹-__²-__³-__⁴

Description:

Single stage air-cooled portable water chiller system with additional process system heat exchanger. System capacity indicated on table is the approximate BTU/hr based on a leaving fluid temperature of 50°F with an ambient air temperature of 95°F.

CAPACITY ±5% AT 50° LCWT / 95°F AMBIENT		90,000 BTU /HR					
COMPRESSOR / REFRIGERANT		HERMETIC SCROLL / R410A					
CONDENSER FANS / AIRFLOW		1 / 5700 CFM					
CONDENSER COILS TYPE		COPPER TUBE / ALUMINUM FIN					
EVAPORATOR TYPE		STAINLESS STEEL / COPPER BRAZED					
HEAT EXCHANGER TYPE		STAINLESS STEEL / COPPER BRAZED					
FLUID CONNECTIONS		1" MNPT (IN/OUT)					
ELECTRICAL:	V - Ø - HZ	COMP RLA / LRA	FAN FLA	PUMP FLA	MCA	MOCP	
- 5	230 - 3 - 60	27.9	164	5.3	3.4	43.5	70
- 6	460 - 3 - 60	13.6	100	2.2	1.7	20.1	30
PUMP HP / OUTPUT		1.0 HP / 30 GPM @ 30 PSI					
TANK SIZE / CONSTRUCTION		41 GALLON / 304 STAINLESS STEEL TANK WITH LID					
DIMENSIONS		66" L x 45" W x 56" H					
WEIGHT (APPROX.)		1000 LBS					

Note: All specifications subject to change without notice. Specify voltage and ambient condition upon ordering.
MCA: Minimum circuit amps per UL 1995. MOCP: Maximum overcurrent protective device per UL 1995.

STANDARD FEATURES:

- **Controls:** Electronic programmed temperature controller with constant (set point & process) temperature readout.
- **Refrigeration Components:** Efficient scroll compressors, sight glass/moisture indicators, balanced port expansion valves, filter drier, pump down valves, fan cycling head pressure controls.
- **Process Fluid Components:** Heat exchanger for separation of chilled fluid circuit from process fluid circuit. Bronze "Y" strainer with 20 mesh stainless steel screen. Pumps are stainless steel centrifugal. Tanks are insulated with shoe box lid, fill port, and level sight glass. Portable systems will include a flow control valve.
- **Safety Controls:** High and low refrigerant pressure, high and low fluid temperature, freeze, low water flow, overloads for compressor and fan motors, safety fuses or overloads for pump.
- **Construction:** Welded steel powder coated frame and full metal cabinet, copper piping connections.
- **Warranty:** One year parts / five year compressor.

SUITABLE AMBIENT CONDITIONS/FEATURES:

- **IND:** Indoor use only. Casters on frame.
- **40:** Suitable for outdoor use with an ambient of 40°F ambient.
- **0:** Suitable for outdoor use to 0°F ambient.
- **M20:** Suitable for outdoor use to -20°F ambient. Includes hot gas bypass.

¹ Flow Design (__=Portable, ST=Stationary, RF=Reverse Flow, EXCH=Extra Heat Exchanger, DP=Dual Pump, DR=Dual Return)

² Leaving Fluid Temperature (__=Standard, LT=Low Temperature-specify lowest temperature in °F)

³ Ambient Temperature Conditions (see above)

⁴ Electrical Power Code (see above)



FRONT VIEW

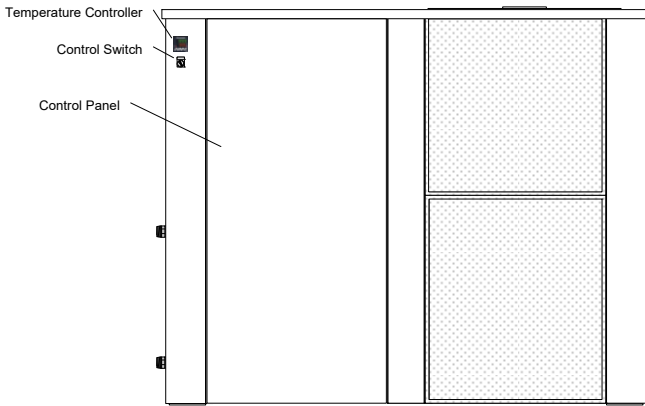

RIGHT SIDE VIEW

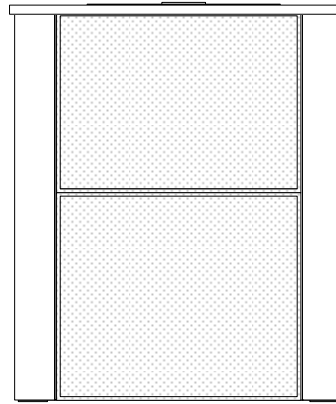

BACK VIEW

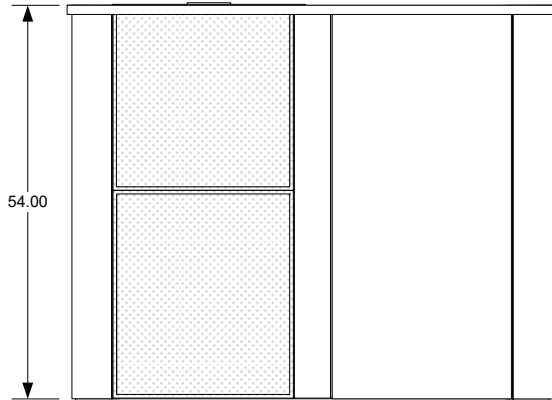

LEFT SIDE VIEW

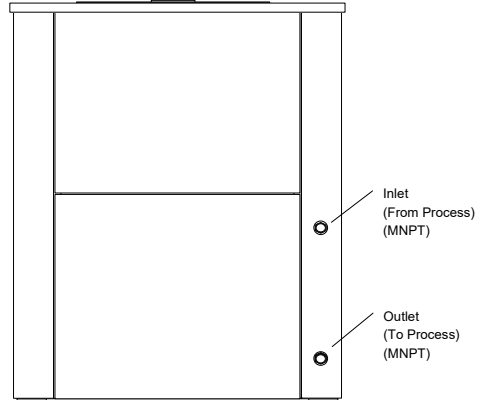

TOP VIEW

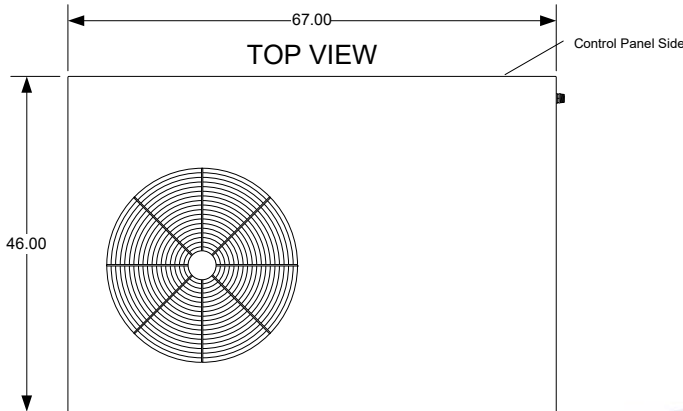

NOTES

- Unit should be installed with at least 2' clearance on all sides and a minimum of 5' clear air space above the unit
- Dimensions are approximate. (inches)
- Casters (Optional)
- All specifications subject to change without notice.

COLD SHOT CHILLERS

DRAWN ENGINEERING

ISSUED 10/20/2021

SIZE	DIMENSION NOTES
A	Dimensions are in inches Unless otherwise specified. +/-1/4"

DWG NO	REV
INSTALLATION DRAWING ACWC-090-Q_ (Typical)	1



HEAT EXCHANGER (EXCH)

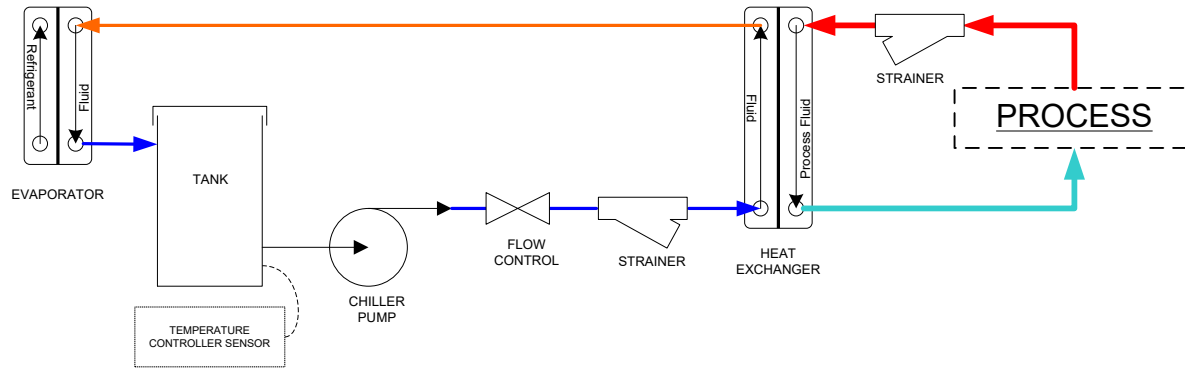

Line Guide

- COLD CHILLED FLUID
- HOT FLUID
- COLD FLUID
- WARM FLUID

NOTES

- All designs are subject to change without notice.
- The diagrams are to be used as a basic flow diagram only.
- Color Code is for relative temperature comparison.
- Additional components may be included.
- Evaporator may be located in tank.

COLD SHOT CHILLERS		SIZE	DESCRIPTION Typical FLOW OPTIONS for Chiller Circuits	REV		
		A		1		
DRAWN	ENGINEERING	SCALE	NONE	DWG-CKT_ChillerCircuitFlowOptions-Typical_(0520).vsd	SHEET	2 / Heat Exchanger (EXCH)
ISSUED	5/2020					