

Cold Shot Chillers

"ECONOMICALLY PRICED DEPENDABILITY"



TECHNICAL SPECIFICATION

Model: WCWC-24-E-__1-__2-__3-__4

Description:

Single stage water-cooled portable water chiller system. System capacity indicated on table is the approximate BTU/hr based on a leaving fluid temperature of 50°F with a condenser water temperature of 85°F.

CAPACITY ±5% AT 50° LCWT / 85°F CONDENSER WT		24,000 BTU /HR				
COMPRESSOR / REFRIGERANT		HERMETIC SCROLL / R-410A				
CONDENSER TYPE		STAINLESS STEEL / COPPER BRAZED				
EVAPORATOR TYPE		STAINLESS STEEL / COPPER BRAZED				
FLUID CONNECTIONS		1" MNPT (IN/OUT)				
ELECTRICAL:	V - Ø - HZ	COMP RLA / LRA		PUMP FLA	MCA	MOCP
- 2	230 - 1 - 60	12.8	58.3	6.6	22.6	35
-6	460 - 3 - 60	5.7	28	1.7	8.8	15
PUMP HP / OUTPUT		1.0 HP / 30 GPM @ 30 PSI				
TANK SIZE / CONSTRUCTION		25 GALLON / 304 STAINLESS STEEL TANK WITH LID				
DIMENSIONS		41" L x 29" W x 52" H				
WEIGHT (APPROX.)		350 LBS				

Note: All specifications subject to change without notice. Specify Voltage and Ambient Condition upon ordering.

MCA: Minimum circuit amps per UL 1995. MOCP: Maximum overcurrent protective device per UL 1995.

STANDARD FEATURES:

- **Controls:** Electronic programmed temperature controller with constant (set point & process) temperature readout.
- **Refrigeration Components:** Efficient scroll compressors, sight glass/moisture indicators, balanced port expansion valves, filter drier, access ports and or service valves, pressure actuated head pressure controls, liquid receiver.
- **Process Fluid Components:** Bronze "Y" strainer with 20 mesh stainless steel screen. Pumps are stainless steel centrifugal. Tanks are insulated with shoe box lid, fill port, and level sight glass. Portable systems will include a bypass flow valve.
- **Safety Controls:** High and low refrigerant pressure, high and low fluid temperature, low water flow, thermal overloads for compressors, safety fuses or overloads for pump.
- **Construction:** Welded steel powder coated frame and full metal cabinet, copper piping connections.
- **Warranty:** One year parts / five year compressor.

SUITABLE AMBIENT CONDITIONS/FEATURES:

- **IND:** Indoor use only. Casters on frame.
- **40:** Suitable for outdoor use with an ambient of 40°F ambient. Casters, optional.
- **0:** Suitable for outdoor use to 0°F ambient. Casters, optional.
- **M20:** Suitable for outdoor use to -20°F ambient. With hot gas bypass. Casters, optional.

¹ Flow Design (__=Portable, ST=Stationary, RF=Reverse Flow, EXCH=Extra Heat Exchanger, DP=Dual Pump, DR=Dual Return)

² Leaving Fluid Temperature (__=Standard, LT=Low Temperature-specify lowest temperature in °F)

³ Ambient Temperature Conditions (see above)

⁴ Electrical Power Code (see above)

Marrone & Co., Inc.

2730 Maximilian Drive, Houston, Texas 77032 • Phone (800) 473-9178, (281) 227-8400

Fax (800) 473- 9175, (281) 227-8404 • www.waterchillers.com

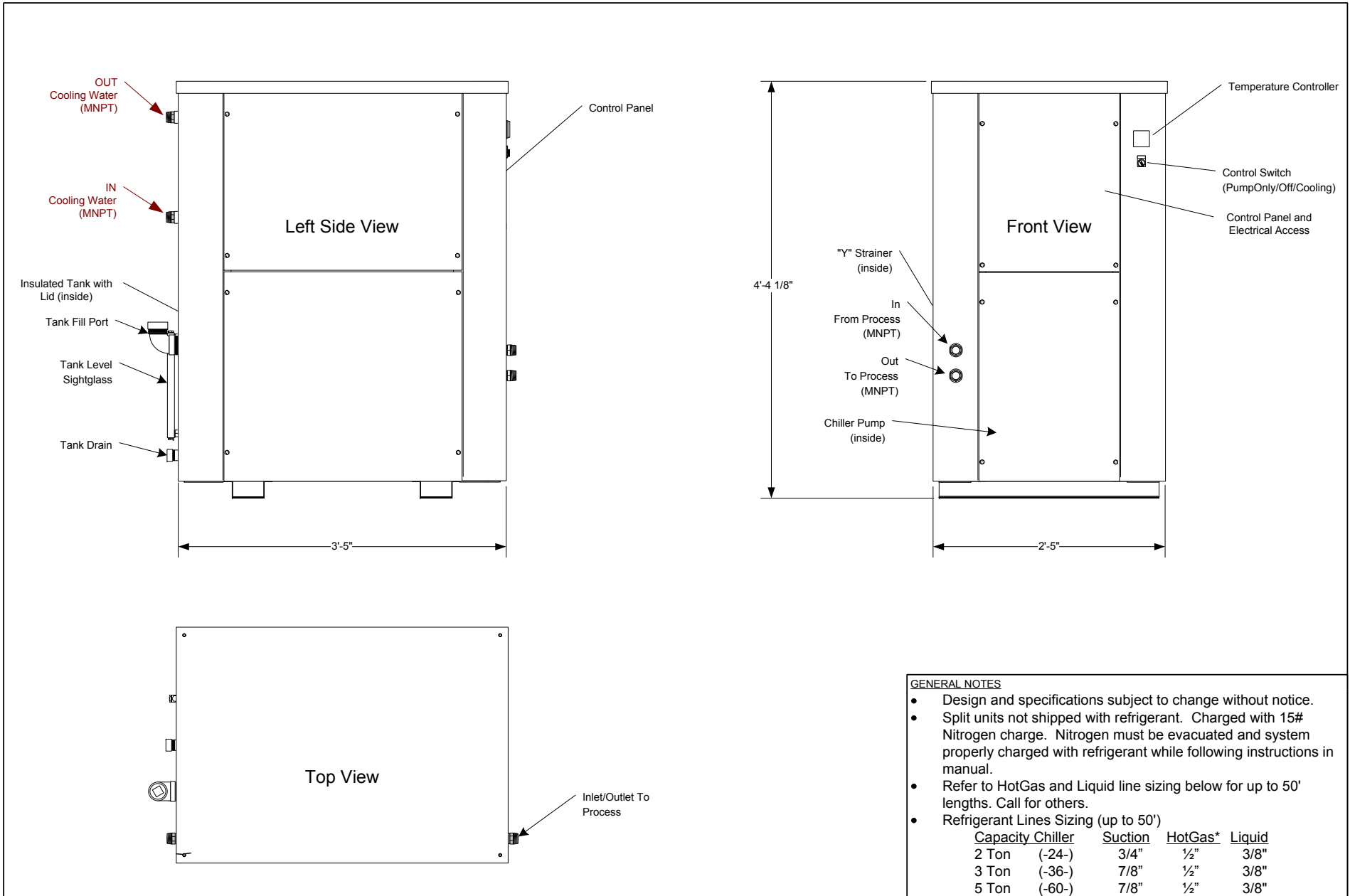

- GENERAL NOTES**
- Design and specifications subject to change without notice.
 - Split units not shipped with refrigerant. Charged with 15# Nitrogen charge. Nitrogen must be evacuated and system properly charged with refrigerant while following instructions in manual.
 - Refer to HotGas and Liquid line sizing below for up to 50' lengths. Call for others.
 - Refrigerant Lines Sizing (up to 50')
- | Capacity | Chiller | Suction | HotGas* | Liquid |
|----------|---------|---------|---------|--------|
| 2 Ton | (-24-) | 3/4" | 1/2" | 3/8" |
| 3 Ton | (-36-) | 7/8" | 1/2" | 3/8" |
| 5 Ton | (-60-) | 7/8" | 1/2" | 3/8" |
| 7.5 Ton | (-90-) | 1 1/8" | 1/2" | 1/2" |

COLD SHOT CHILLERS		SIZE	DIMENSION NOTES	DWG NO	REV
		A	Dimensions are in inches Unless otherwise specified.	INSTALLATION DRAWING WCWC-24/36/60/90-E Chiller Section (Typical)	1
DRAWN	ENGINEERING	SCALE	None	DWG-INST_WCWC-24'36'60'90-E(Chiller)_(0514).vsd	SHEET 1 / ChillerSection Front-Left-Top
ISSUED	3/16/2016				

STANDARD/PORTABLE/PACKAGE (-)

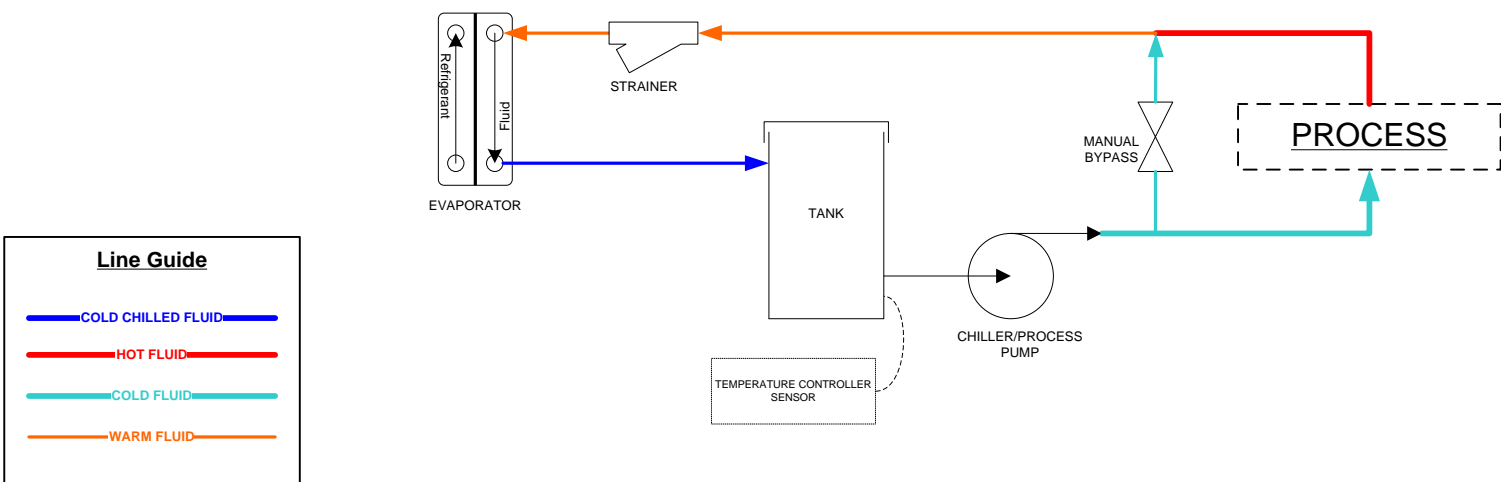

Line Guide

- COLD CHILLED FLUID
- HOT FLUID
- COLD FLUID
- WARM FLUID

NOTES

- All designs are subject to change without notice.
- The diagrams are to be used as a basic flow diagram only.
- Color Code is for relative temperature comparison.
- Additional components may be included.
- Evaporator may be located in tank.

COLD SHOT CHILLERS

DRAWN ENGINEERING

ISSUED 6/21/2018

SIZE A

SCALE NTS

Typical FLOW OPTIONS for Chiller Circuits

DWG-CKT_ChillerCircuitFlowOptions-Typical_062218.vsd

DESCRIPTION
REV 1

SHEET 1 / Standard/Portable